

**Syntron®
Working with
Isolation**

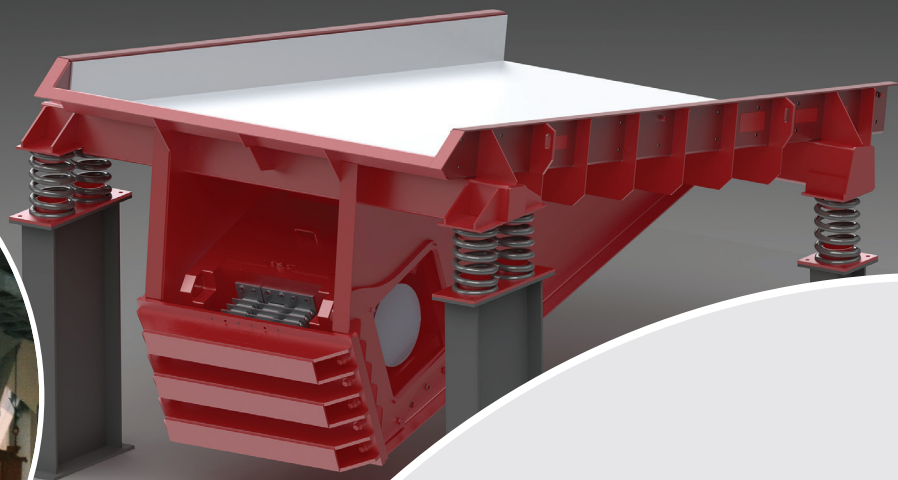

Contents

Syntron® Working with Isolation

Purpose	4
Base Mounting.....	5
Base Mounting Views.....	6
Snubbers and Tag Lines.....	7
Suspension Mounting.....	8
Suspension Hanger Views.....	9
Hanger Orientation	10
Wire Rope and Hardware	11
Suspension Cable Whip.....	12
Swaged End Wire Rope and Views	12
Turnbuckles and Rods.....	13
Safety Cables	14
Link Bars and Connections.....	15
Link Bar for Electromechanical Feeders	15
Link Bar for Electromagnetic Feeders.....	16
Suspension Lug Drawing.....	16
Isolation Tilt, Tilt Views and No Tilt Views.....	17
Wire Rope Diameter Chart	18



Syntron Material Handling

Proven Engineered Products – Complete Material Handling Solutions

Two powerful industry leading brands—**Link-Belt®** and **Syntron®**—have come together under a new company name, Syntron Material Handling, LLC, for one goal – better engineered products.

Established in May 2014, Syntron Material Handling (SMH) was built out of the legacies of Link-Belt Company and Syntron Company, formerly owned by FMC Technologies. Today, our 300 skilled employees have a combined 4,212 years of industry knowledge that they put into the SMH product every day. We are dedicated to providing customers with complete material handling solutions.

Let Syntron Material Handling's knowledgeable team help your business with conveying, feeding, screening, elevating, vibratory flow aids, and mining controls of bulk product. Whether optimizing existing systems or starting from the ground-up on new and customized plants or mines, our dedicated staff will provide you with the most efficient and cost-effective solutions.

"Our company structure will be very exciting and fast-paced as we charter our new path. The positive attitudes and skills of our employees, the strength of our products, and our long-term customer relationships are our foundation for success." said CEO Andy Blanchard.

An international leader for innovative solutions, Syntron Material Handling can improve the technology customers are already using. The Link-Belt® expertise and equipment have been instrumental in developing some of the world's largest belt conveyors. The Syntron® feeders are instrumental to supplying energy sources and material handling efforts across the globe.

Levine Leichtman Capital Partners, the new owner of Syntron Material Handling, is committed to the success and growth of the company by investing in engineering capabilities, manufacturing efficiency, and customer service.

Although we may have a new name, we still have the same dedicated employees and industry leading engineered products that make us a market leader.

Syntron Material Handling operates two manufacturing facilities in the USA and China.

All of our products are produced to OSHA/MSHA standards and ISO Standard 9001:2008. We are a charter member of CEMA, and active members of NSSGA, NMA, SME, FEMA, and PMMI.



Call us today for all your material handling needs.

Saltillo
2730 Hwy 145 South
Saltillo, Mississippi 38866
Phone: 662.869.5711
Fax: 662.869.7493
800.356.4898
orders@syntronmh.com

Changshu
#2 Road No. 1
Changshu Export Processing Zone
Changshu, Jiangsu, China 215513
Phone: +86 0512.52299002
Fax: +86 0512.52297228

Purpose

This book is provided by Syntron Material Handling as an aid to answer common questions relating to vibratory equipment isolation.

The purpose of this book is to discuss the recommended methods for installing vibratory equipment isolation systems. It will address both suspension and base mounting along with the installation of safety cables. Since most vibratory equipment is suspension mounted, it will be the primary focus.

Proper wire rope and various hardware items will be reviewed to ensure the installation will allow the vibratory equipment to perform properly.

In addition, the common problems related to improper installations will be discussed.



Suspension Mounted Feeder

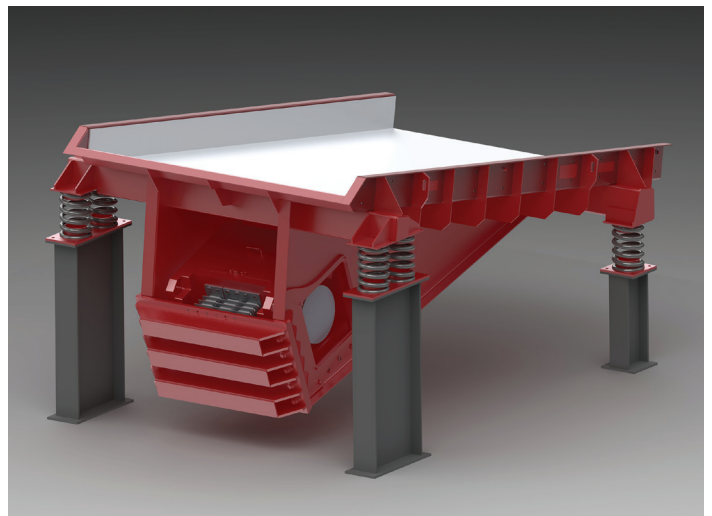

Base Mounted Feeder

Base Mounting

Base mounted vibratory equipment sits directly on some type of isolation spring, which can be either steel coil, polymeric, or pneumatic. These springs are then mounted on seats which attach to stationary support structure.

The support structure must be designed to withstand: the static unit weight as shown on the equipment general arrangement drawing(s), the static material weight, the horizontal dynamic weight and the vertical dynamic load. If the previously listed weights or loads are not known, contact Syntron Material Handling.

In addition to the static and dynamic loads, the structure must be designed to ensure there are no structural frequencies at or close to the operating frequency of the vibratory equipment. If the operating frequency is not known, contact Syntron Material Handling. Excess movement in the support structure can adversely affect the operating characteristics of the vibratory equipment and, in some instances, cause damage to the vibrating equipment or the isolation springs.

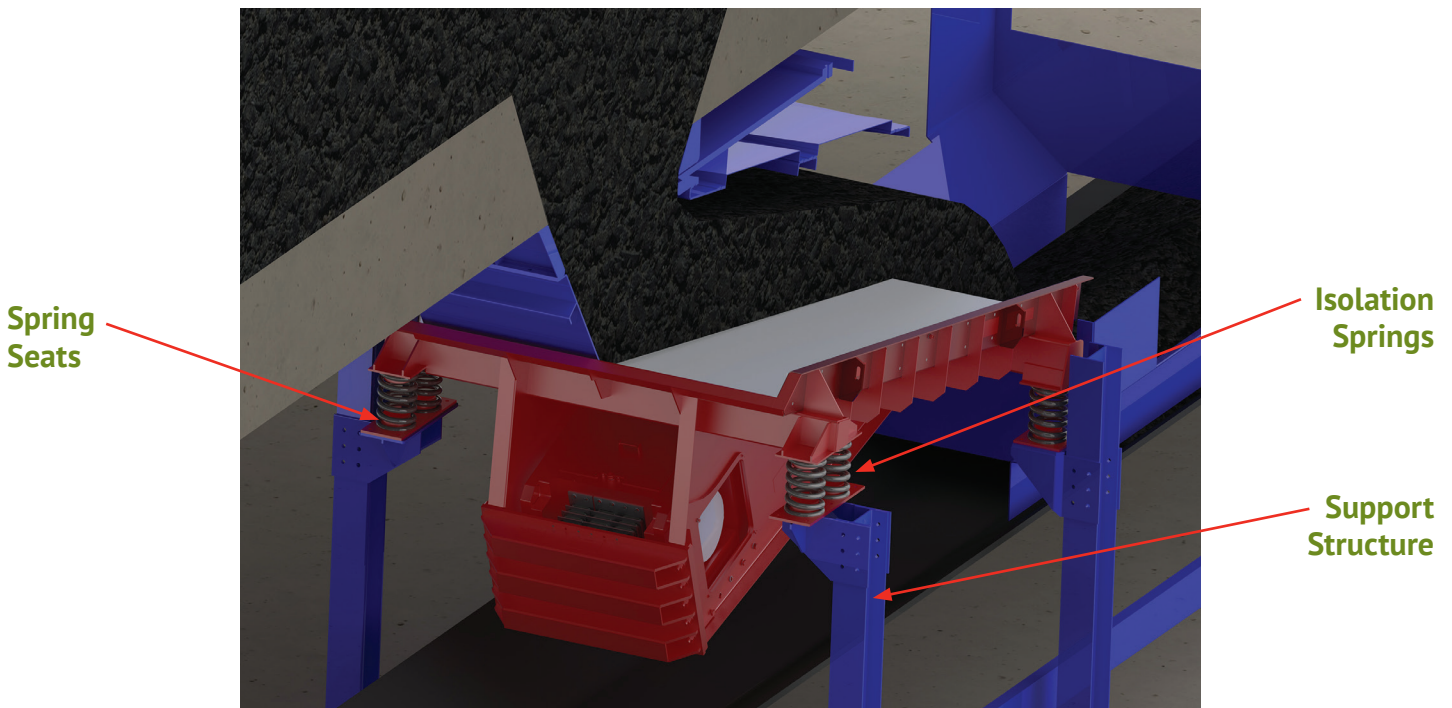

Base Mounting Views

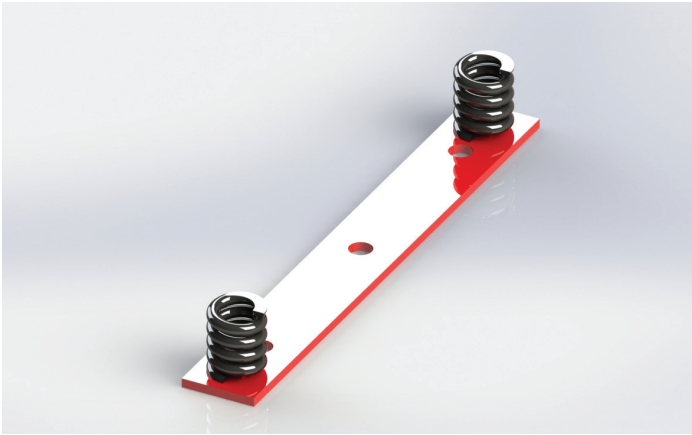

**Inlet End of an
Electromagnetic Feeder**

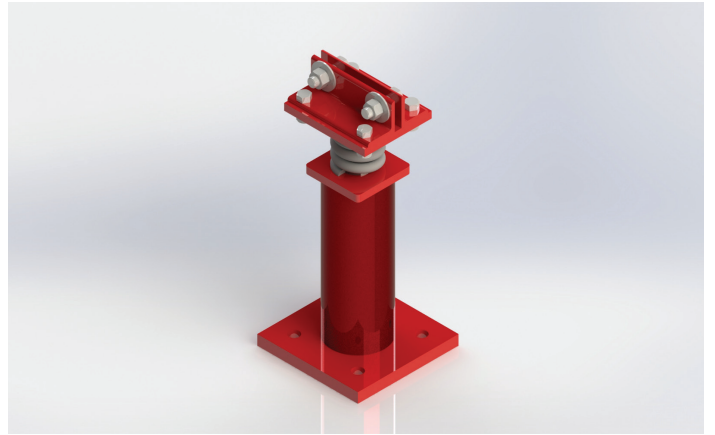

**Discharge End of an
Electromagnetic Feeder**



**Electromechanical Feeder –
Dual Spring**



**Electromechanical Feeder –
Single Spring**



Screen Dual Spring

Snubbers and Tag Lines

On some base mounted brute force feeders and screens it is necessary to install snubbers. This is usually a spring-loaded device which rubs against pads on each of the four corners of the vibrating equipment. These snubbers are designed to help reduce side motion.

Due to certain installation conditions, some suspension mounted brute force feeders and screens experience unwanted side motion and sway. In these situations, it is customary to install tag lines (see below tag line drawing). However, consult Syntron Material Handling prior to installation.



Screen Dual Spring

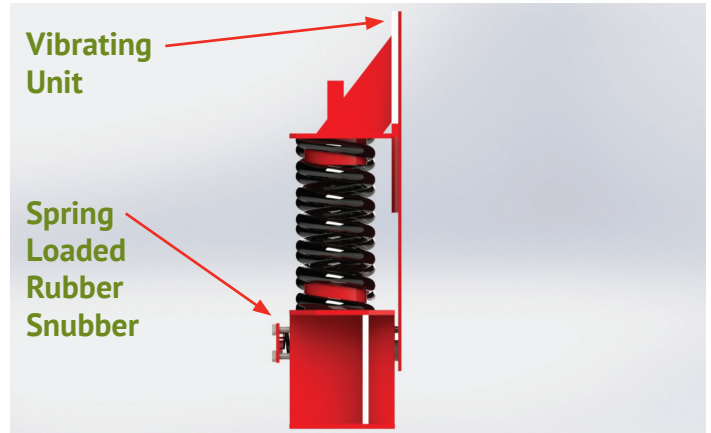

Rubber Spring Snubber

Tag Line Drawing

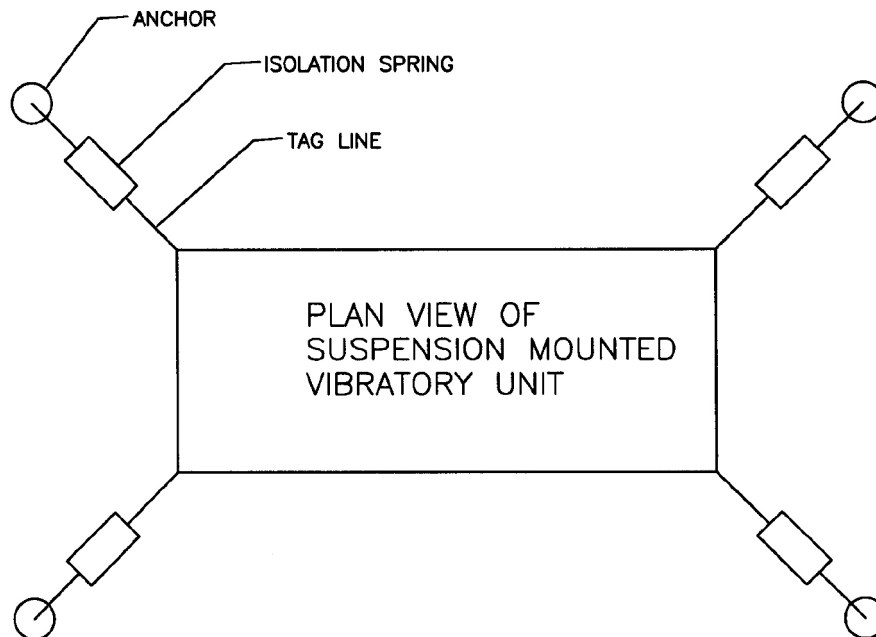

Suspension Mounting

Suspension mounted vibratory equipment hangs from isolation assemblies which are attached to the overhead stationary support structure. The support structure must be designed to withstand: the static unit weight as shown on the equipment general arrangement drawing(s), the static material weight, and the vertical dynamic load. If the previously listed weights are not known, contact Syntron Material Handling.

There are no horizontal loads on suspension mounted equipment if installed properly. This is an advantage because the required

support structure can be lighter and the probability of structural frequency problems is significantly less.

Note the orientation of the suspension bails in the picture below. The pin connection through the bails should be oriented as shown with the plates parallel to material flow. This allows free movement of the hanger assembly and prevents unwanted stress in the hanger. See page 10 for other examples.



Suspension Hanger Views



**Electromechanical
RF Hanger**



**Electromechanical
MF Hanger**

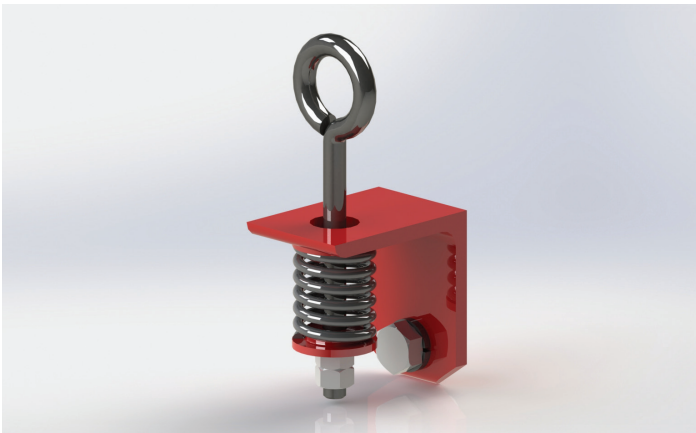

**Electromagnetic
Angle Hanger**



**Electromagnetic
Bail Hanger**

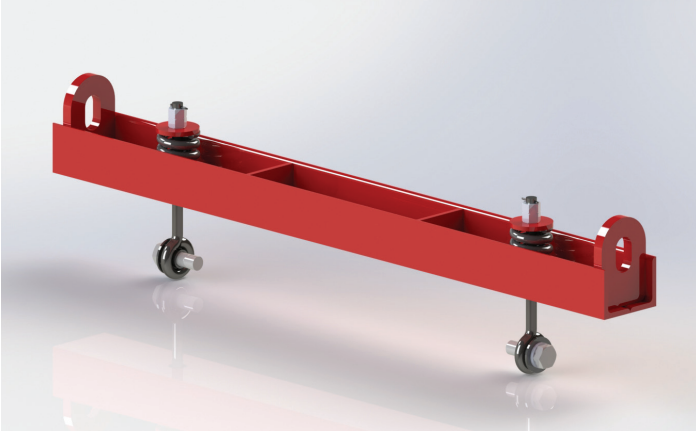

**Electromagnetic
Inlet Beam Hanger**

Hanger Orientation Relative to Material Flow

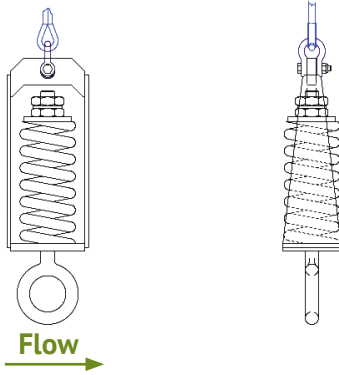

Suspension Hanger With Wire Rope

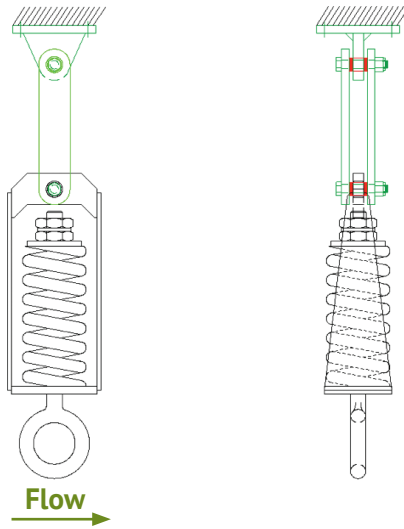

Suspension Hanger With Link-bars

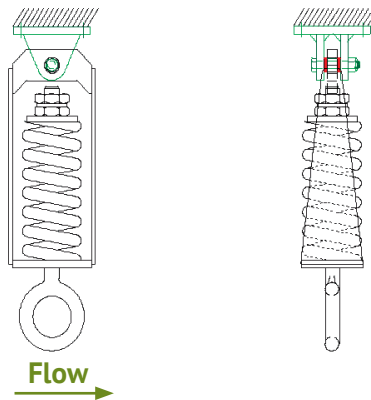

Suspension Hanger With Lug

Wire Rope and Hardware

Syntron Material Handling recommends the use of flexible wire rope for suspension mounted vibratory equipment as the best way to attach the isolation hangers to the rigid structure. The wire rope should be 6 x 25 (6 x 19 class) filler wire yellow strand preformed IWRC core right lay regular lay or equal pre-stressed to avoid stretching. The recommended wire rope size is as shown on page 19 of this book and in the service instruction manual for the specific equipment. Extra heavy wire rope thimbles and drop

forged clips should be used and installed per the clip manufacturer recommendations.

If shackles are used, Syntron Material Handling recommends drop forged anchor type safety shackles (Crosby style S-2130). This type of shackle employs bolt and locked nut type pins which will not work loose under vibration. The size of the shackle should be equal to or greater than the size of the wire rope.

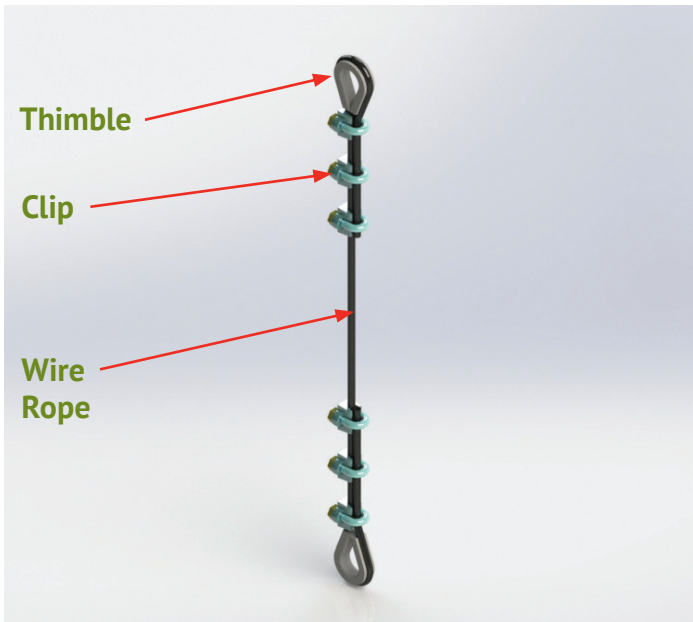

**Suspension Cable
(Standard)**

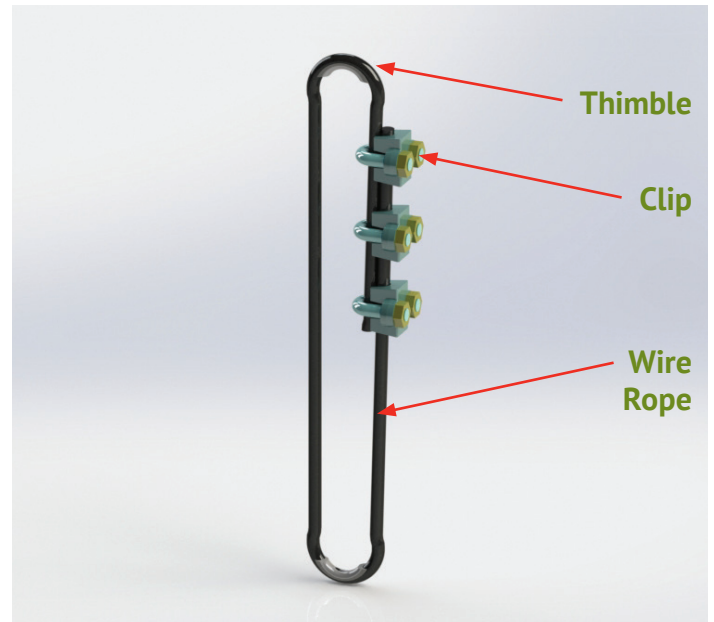

**Suspension Cable
(Short Single Loop)**

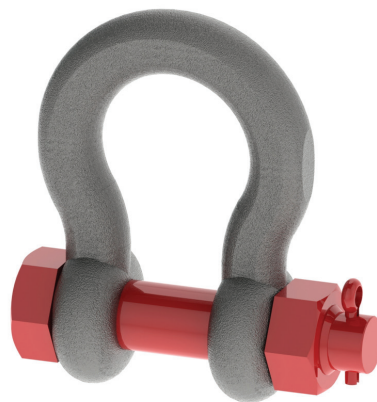

Anchor Safety Shackle

Suspension Cable Whip

In some situations, even when the vibrating equipment is suspended with the proper wire rope, the wire rope will whip. This whip is usually caused by either improperly adjusted tension or by the natural frequency of the wire rope assembly being too close to the operating frequency of the vibrating equipment. Whip is usually associated with cables that are quite long.

If the suspension wire rope assembly whips, the first step is to check for even loading on all suspension points. If one point is not adequately loaded the suspension hanger will not isolate and will cause the cable to whip. This can be solved by adjusting the

wire rope length to provide more even tension. In some cases the isolation assembly has adjustment for this purpose.

If the wire rope assembly continues to whip after tension has been checked it can then be assumed the natural frequency of the wire rope assembly is too close to the operating frequency of the vibrating equipment. The solution for this is to attach a cable weight to the midpoint of the wire rope assembly. The amount of weight to be added should be equal to the weight of the wire rope assembly.

Swaged End Wire Rope

Wire rope assemblies with swaged end fittings are also acceptable. However, there are several areas of precaution.

When sizing the swaged end wire rope assembly, the wire rope diameter recommended by Syntron Material Handling should be used. This will ensure the wire rope assembly will be flexible enough to allow the equipment to operate properly. Sizing should not be a function of the swaged end because this usually results in wire rope that is too stiff and too large in diameter. In addition, the final assembly must be long enough to have enough wire rope to remain flexible. If the assembly is too short there will

not be adequate wire rope between the swaged ends to allow proper flexibility, thus, the equipment will not operate properly. The assembly should have a minimum of 20 times the wire rope diameter in free rope between the swaged ends.

When swaged end wire ropes are used it is also very important to specify the end type (eye or jaw) and pin relationship (parallel or at right angles). In addition, it is very important to specify pre-stressed wire rope. This will ensure the ends stay in the desired position and will not rotate the isolation assemblies into an undesired position.

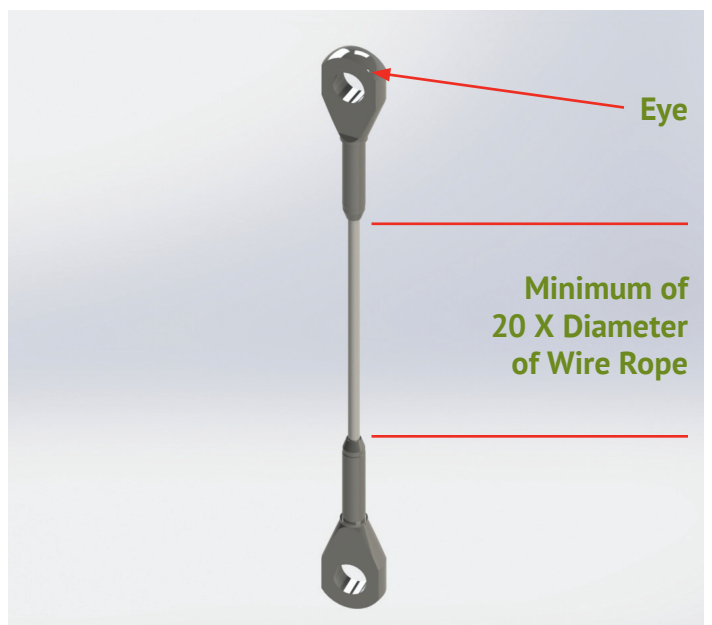
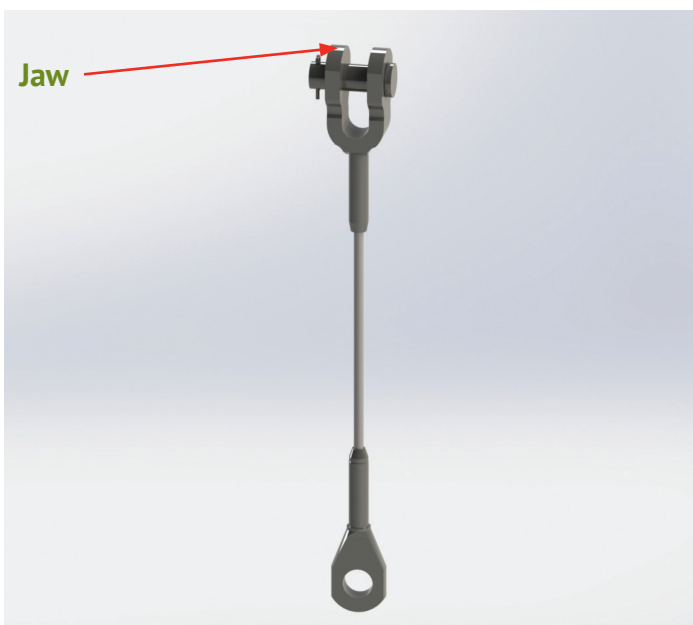

Turnbuckles and Rods

Syntron Material Handling does not recommend the use of turnbuckles or rods. Turnbuckles are generally used to make initial installation of equipment easier or to make slope adjustments to the vibratory equipment. However, the potential problems may far outweigh any perceived benefits.

First, in the case of easier initial installation, the turnbuckles must be drilled and pinned and locking jam nuts must be installed. The time it takes to do this offsets the time it takes to install wire rope. If the turnbuckles are not locked properly they can unwind due to vibration. This will cause the unit to drop and come in contact with stationary structure causing potential damage.

The feeder slope should be set as specified by Syntron Material Handling and should not require adjustment. Changes in the

capacity should be achieved through the use of a variable control. If it is easy to adjust, it is easy for the unit to accidentally contact the stationary structure and damage will result. Furthermore, after initial installation the turnbuckles should be pinned and locked. This will make the task of adjustment much more difficult.

Another reason to avoid the use of turnbuckles is that sizing is critical. If turnbuckles are sized too small they will break the threads due to vibration. Over-sized and even correctly sized turnbuckles carry a risk of causing isolation assembly failures due to added mass on the isolation system.

Turnbuckles have been used in some installations with no noticeable problems. However, the risks outweigh the benefits and they are not recommended.

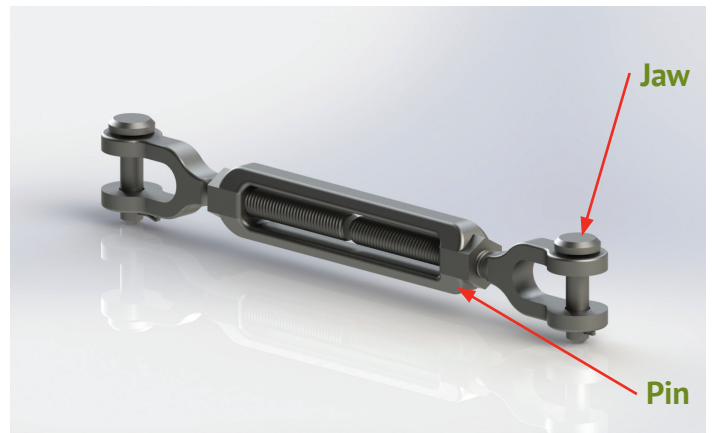
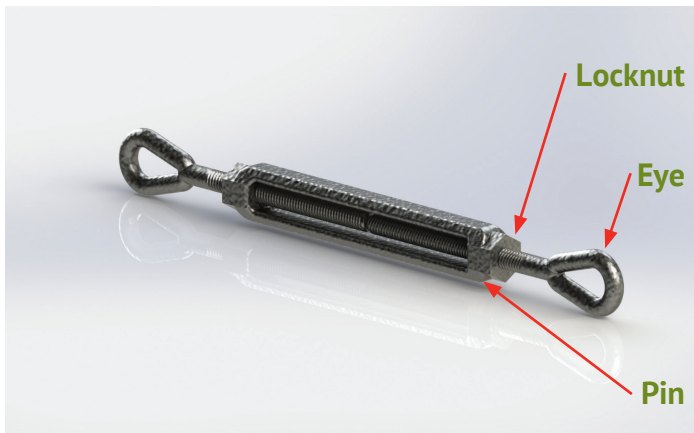

Safety Cables

Syntron Material Handling recommends the use of safety cables on all suspension mounted vibratory equipment. The wire rope should be 6 x 25 (6 x 19 class) filler wire yellow strand preformed IWRC core right lay regular lay or equal. The recommended wire rope size is as shown in the service instruction manual for the specific equipment. Extra heavy wire rope thimbles and drop forged clips should be used and installed per clip manufacturer recommendations.

If shackles are required, Syntron Material Handling recommends drop forged anchor type safety shackles (Crosby style S-2130). This type of shackle employs bolt and locked nut type pins which will not work loose under vibration. The size of the shackle should be equal to or greater than the size of the wire rope.

Safety devices can be in the form of two slings; one at each end of the vibratory equipment or individual cable assemblies at each of four corners. The safety slings should not contact the vibratory equipment but should be positioned to catch the unit if an isolation system should fail. If individual safety cables are used at each corner there must be slack at all times. To prevent wear, tensioning devices such as bungee cords or spring tensioners should be installed between the centers of the individual safety cable assemblies on each side of the unit. This will provide tension and will keep wear at the attachment points to a minimum.

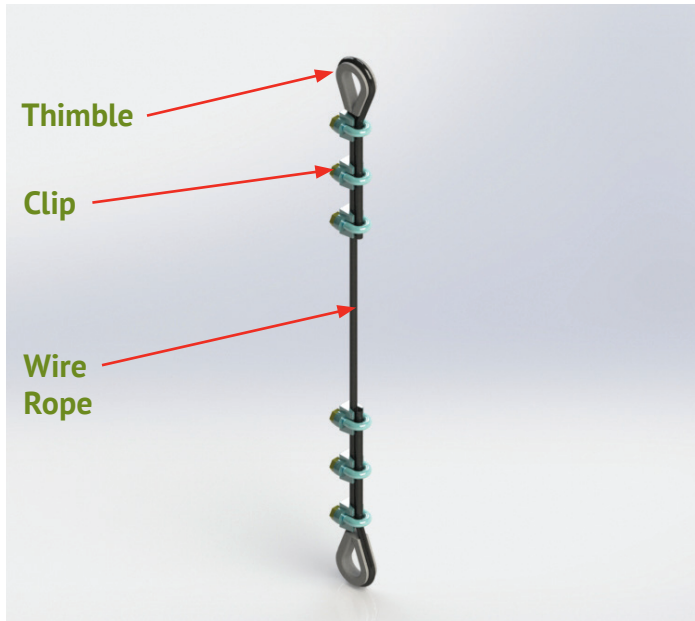

Safety Cable

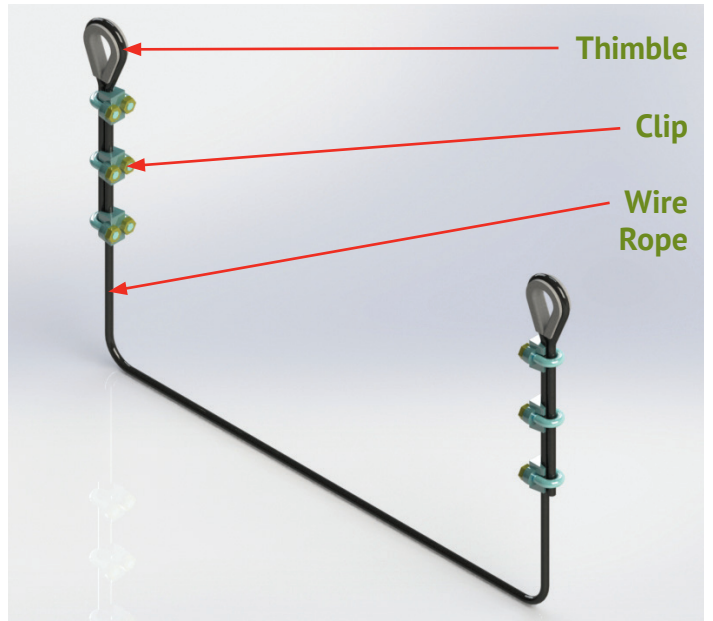

Safety Sling

Note: Install thimbles and clips in accordance with manufacturer's recommendations.

Link Bars and Connections

When the recommended wire rope assemblies become too short to be assembled in accordance with wire rope manufacturer recommendations due to installation requirements, Syntron Material Handling suggests the use of link bar assemblies.

Link bar assemblies consist of two parallel plates, bushings, bolts, and lock nuts. The outside diameter of the bushing is sized to be $1/16$ " less than the inside diameter of the lug, hanger assembly hole, or eyebolt inside diameter it must fit in. The minimum bushing wall thickness is $1/8$ ". The inside diameter of the bushing is also $1/16$ " greater than the bolt diameter. The bushing length is $1/8$ " greater than the lug thickness, hanger thickness, or eyebolt diameter. The holes in the parallel plates are $1/16$ " greater than the

bolt diameter and the width and thickness is sized accordingly to the loads.

The bolts in the link bar assemblies must be perpendicular to the flow of material. The link bar assemblies must be free to pivot and must be vertical in all views.

When link bars become too short to allow for clearance between the top of the hanger assembly and lug it is acceptable to use a single pin parallel plate connection. The parallel plates must be sized for the loads and a bushing, bolt, and locknut must be used as in the link bar assembly described earlier.

Link Bars – Electromechanical

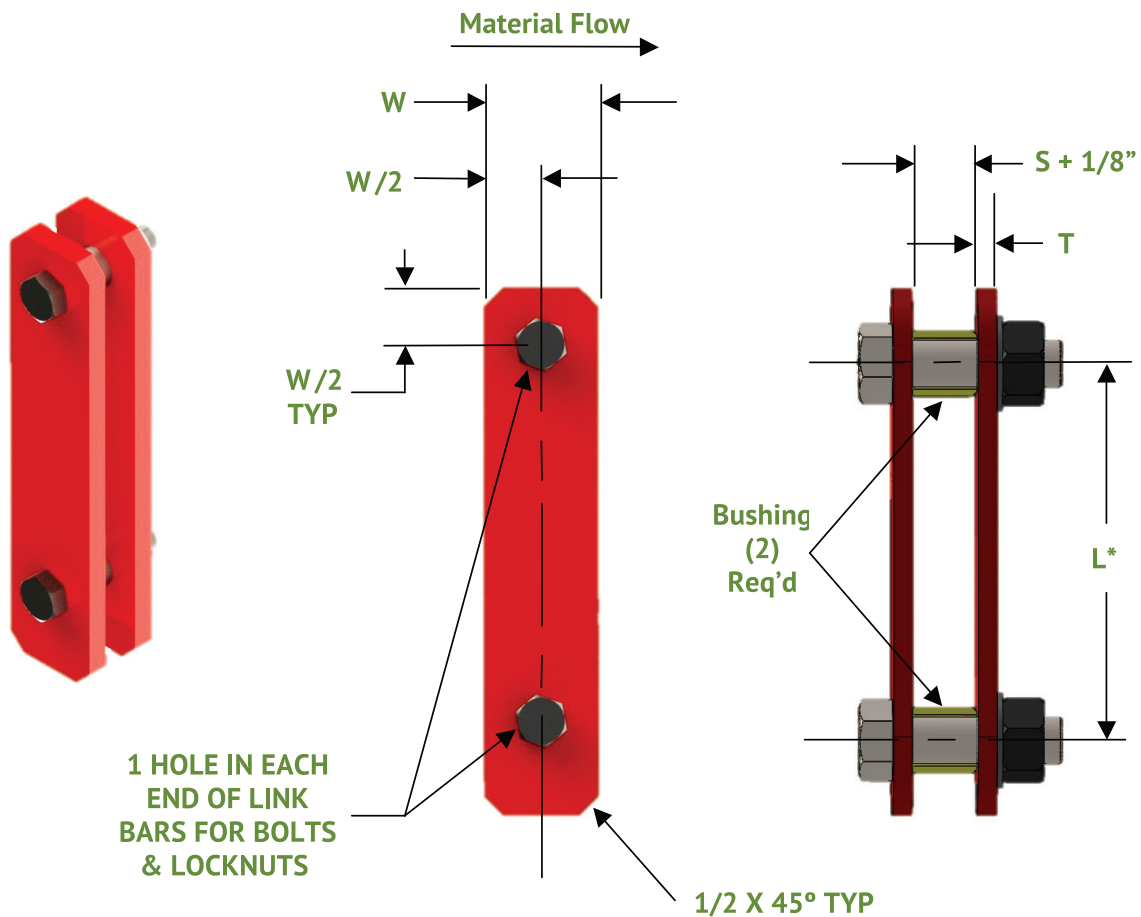

***Note:** L dimension must be reduced by $3/4$ " to allow for static feeder weight.

Link Bars – Electromagnetic

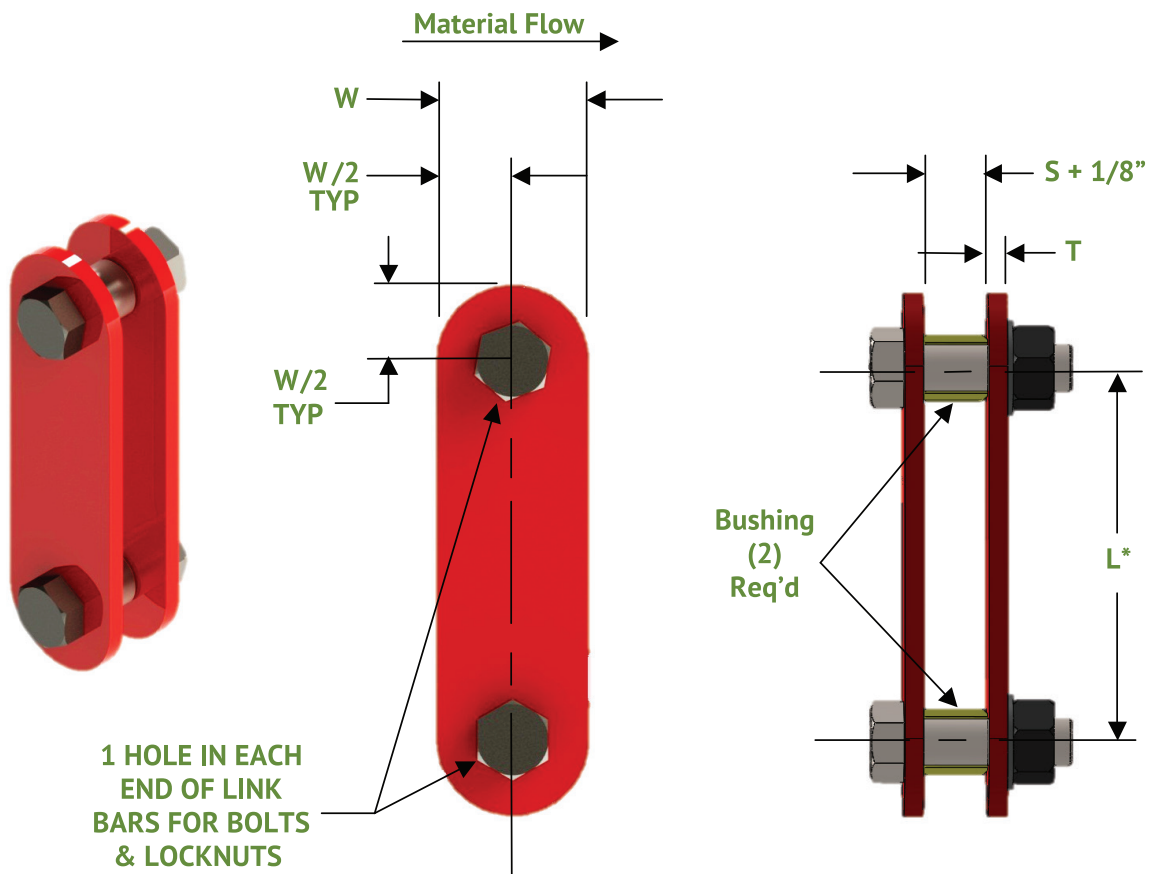

*Note: L dimension must be reduced by $1/4"$ to allow for static feeder weight.

Suspension Lug (supplied by customer)

Single Vertical Plate

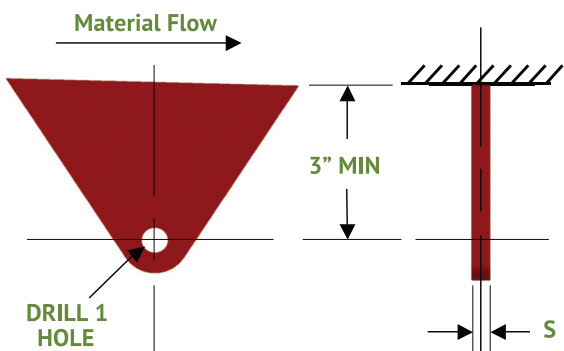

Double Vertical Plate

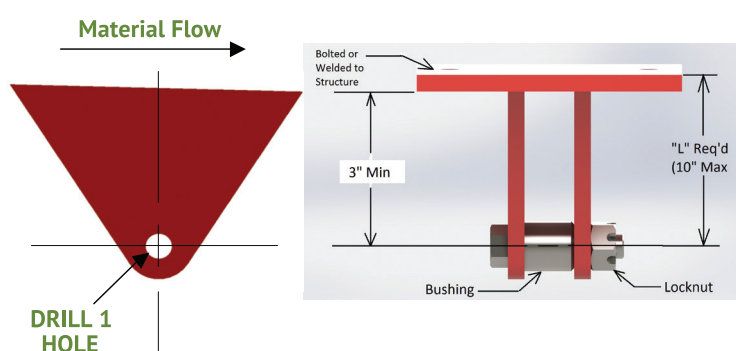

*Note: Option for electromagnetic or electromechanical feeders.

Isolation Tilt

All isolation hanger assemblies must be vertical in the direction of flow to avoid excessive movement and potential spillage or damage. When hooks are supplied on the equipment the isolation hanger assemblies may be tilted perpendicular to flow when flexible wire rope is used to secure the hangers to fixed structure. The specific general arrangement drawing will indicate the maximum degree of tilt that is allowable.

It is important to note that when link bars are used the isolation hanger assemblies must be vertical. This also holds true when

hooks are supplied on the vibratory equipment. Link bars will not allow the proper amount of clearance required to provide adequate freedom of rotation of the joint.

When parallel plate connections are supplied on the vibratory equipment the isolation hanger assemblies must be vertical. When angle bracket isolation assemblies are used the hangers must be perpendicular to the angle bracket spring seat.

Tilt Views

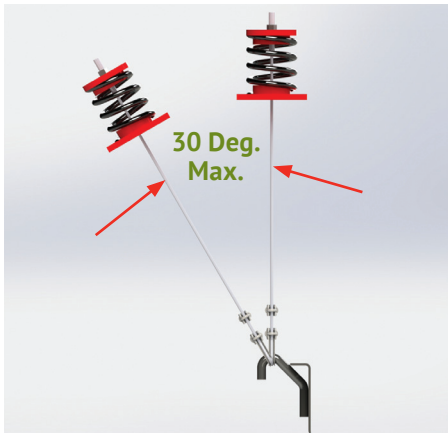

RF Hanger

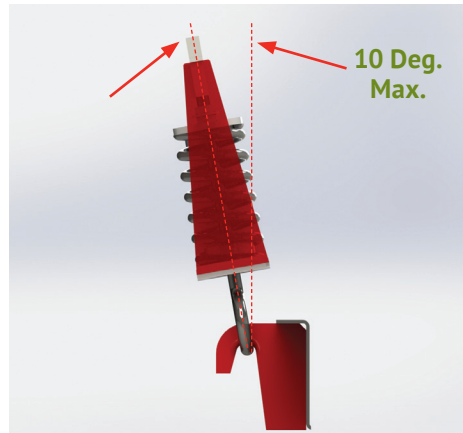

MF Hanger



Magnetic Bail Hanger

No Tilt Views



Mechanical Parallel Plates

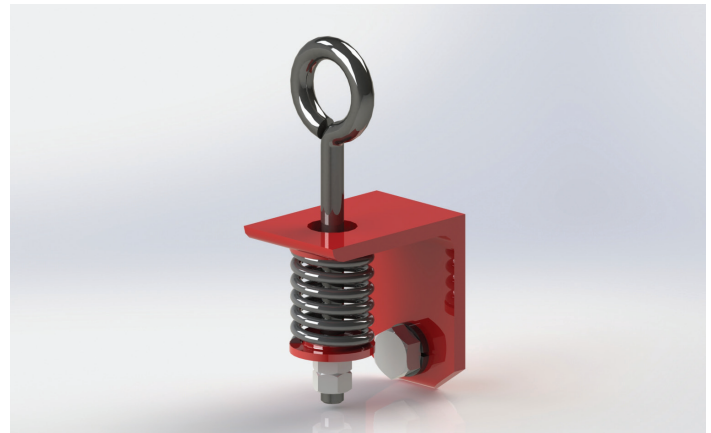

Magnetic Angle Bracket

Recommended Wire Rope Sizes

Feeder Model	Inlet Rope Diameter (Inches)	Discharge Rope Diameter (Inches)
RF-20	3/16	3/16
RF-40	1/4	1/4
RF-80	1/4	1/4
RF-120	5/16	5/16
MF-200/MF-200-DD	3/8	3/8
MF-300/MF-300-DD	3/8	3/8
MF-400/MF-400-DD	1/2	3/8
MF-500-DD	1/2	3/8
MF-600/MF-600-DD	5/8	1/2
MF-800/MF-800-DD	3/4	5/8
MF-1000/MF-1000-DD	7/8	3/4
MF-1100-DD	7/8	3/4
MF-1600	1	3/4
MF-2000	1 1/8	7/8
F-22	3/8	1/4
F-220	3/8	1/4
FH-22	3/8	1/4
F-280	3/8	1/4
FH-24/FH-24-HP	3/8	1/4
F-33	3/8	1/4
F-330	3/8	1/4
F-380/F-380-HP	3/8	1/4
F-44	1/2	3/8
F-440	1/2	3/8
F-45	1/2	3/8
F-450	1/2	3/8
FH-45	1/2	3/8
F-480/F-480-HP	1/2	3/8
F-55	3/4	1/2
F-560	3/4	1/2
F-66	3/4	1/2
F-660	3/4	1/2
F-86	7/8	5/8
F-88	7/8	5/8
F-98	1	7/8



Syntron Material Handling

Corporate Office

P.O. Box 1370

Tupelo, Mississippi 38802

Phone: 662.869.5711

Fax: 662.869.7449

Proven Engineered Products – Complete Material Handling Solutions

Syntron®

Link-Belt®

Salttilo

2730 Hwy 145 South

Salttilo, Mississippi 38866

Phone: 662.869.5711

Fax: 662.869.7493

Toll Free: 800.356.4898

info@syntronmh.com

Changshu

#2 Road No. 1

Changshu Export Processing Zone

Changshu, Jiangsu, China 215513

Phone: +86 0512.52299002

Fax: +86 0512.52297228

info@syntronmh.com